

Ignition Systems

Or.....

How to be a bright spark

Magneto Operation

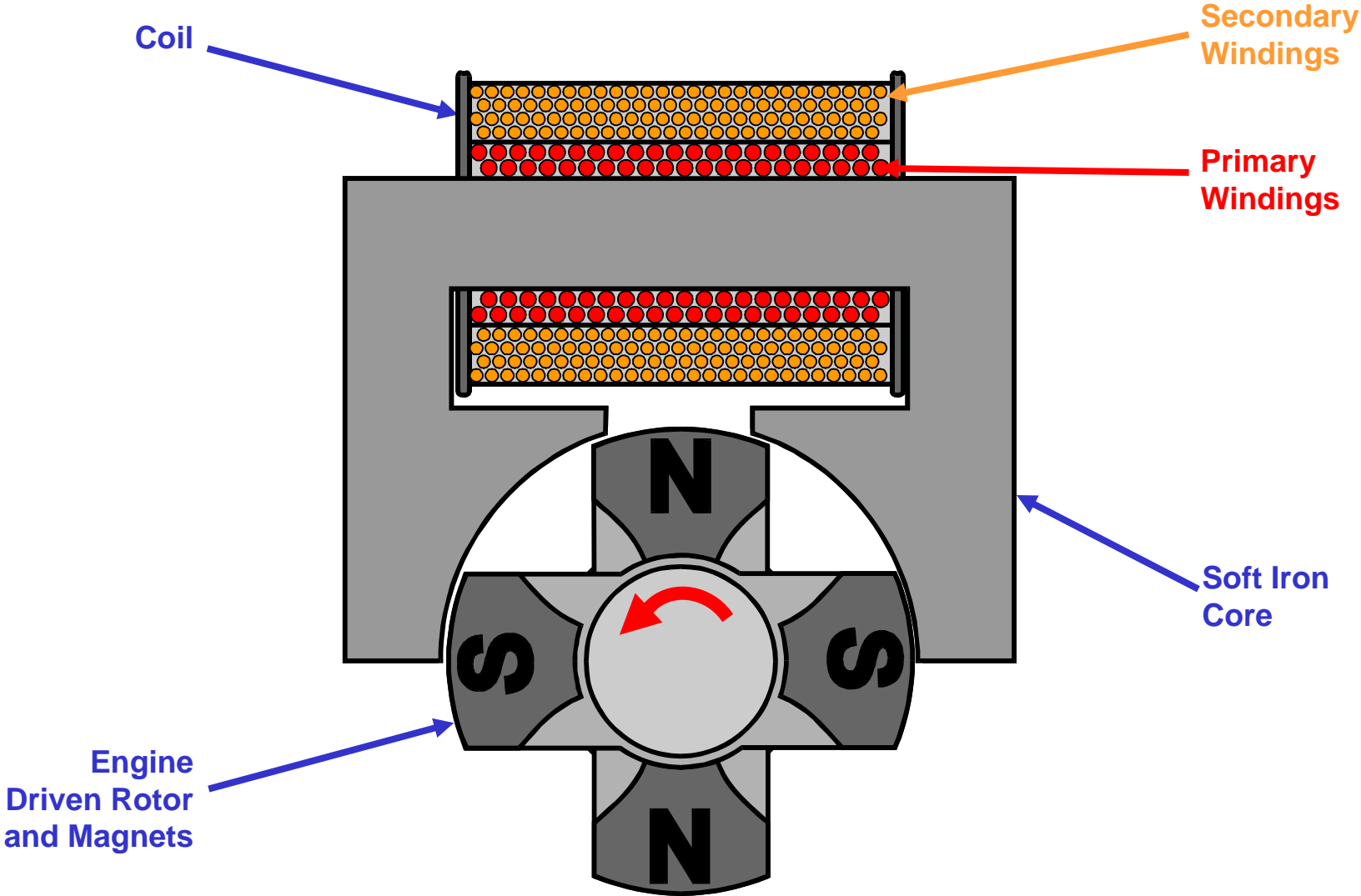

IGNITION SYSTEM

Principal -

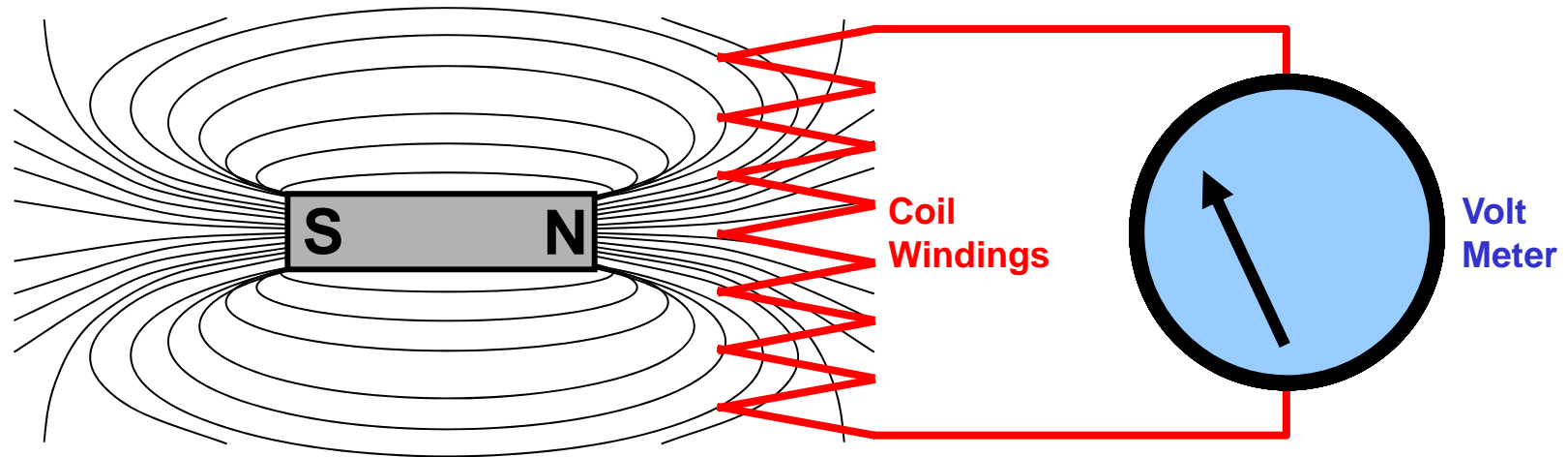

Each time the magnetic field 'washes' through wires

An electrical current is produced

Called an EMF – Electro Motive Force

IGNITION SYSTEM – Faraday Law

Magneto Operation

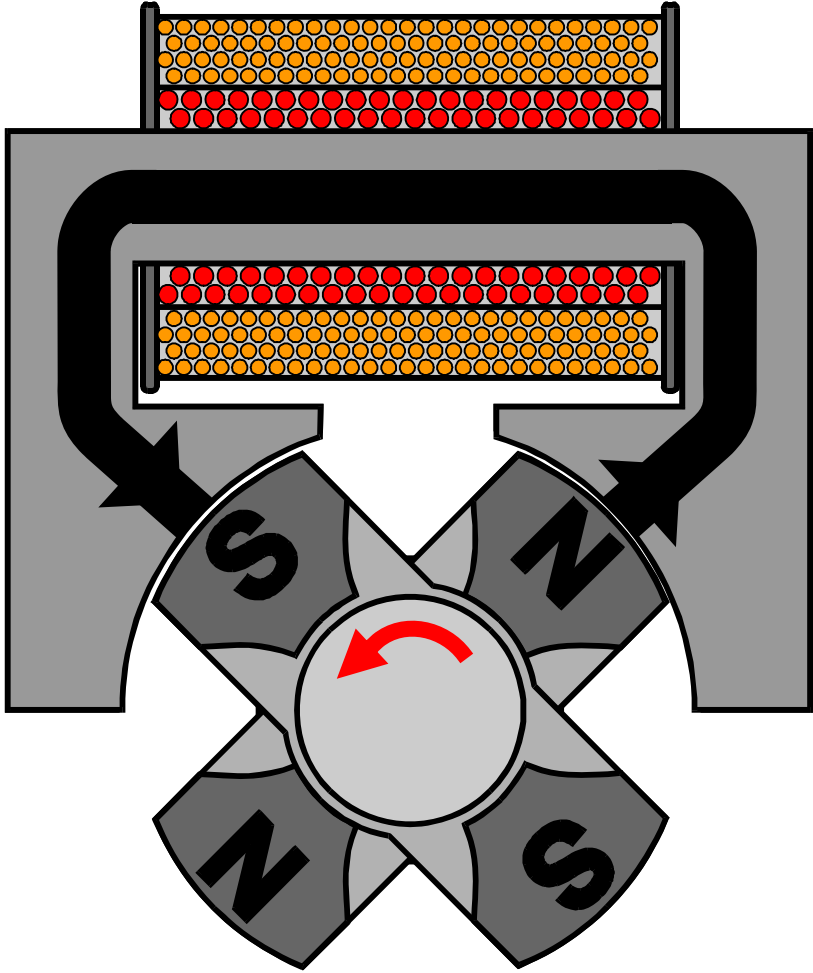

EMF produced in the coil windings

The magnetic field passes through soft iron core

IGNITION SYSTEM

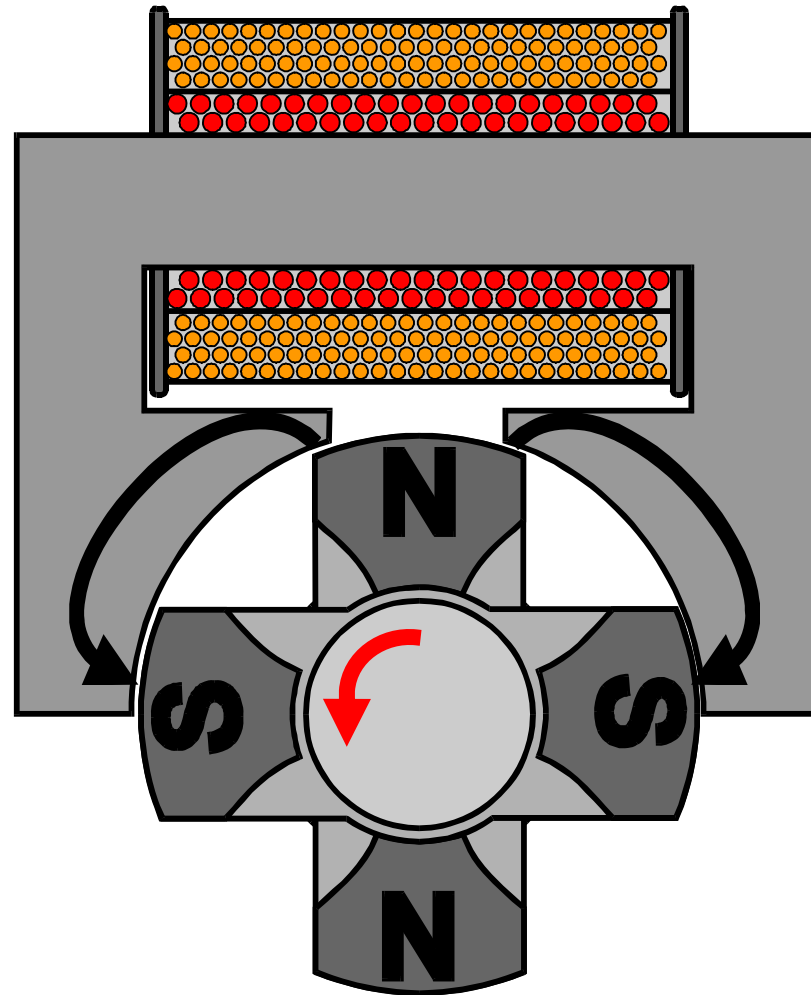

No EMF produced
in the coil windings

No magnetic
field in soft iron
core

IGNITION SYSTEM

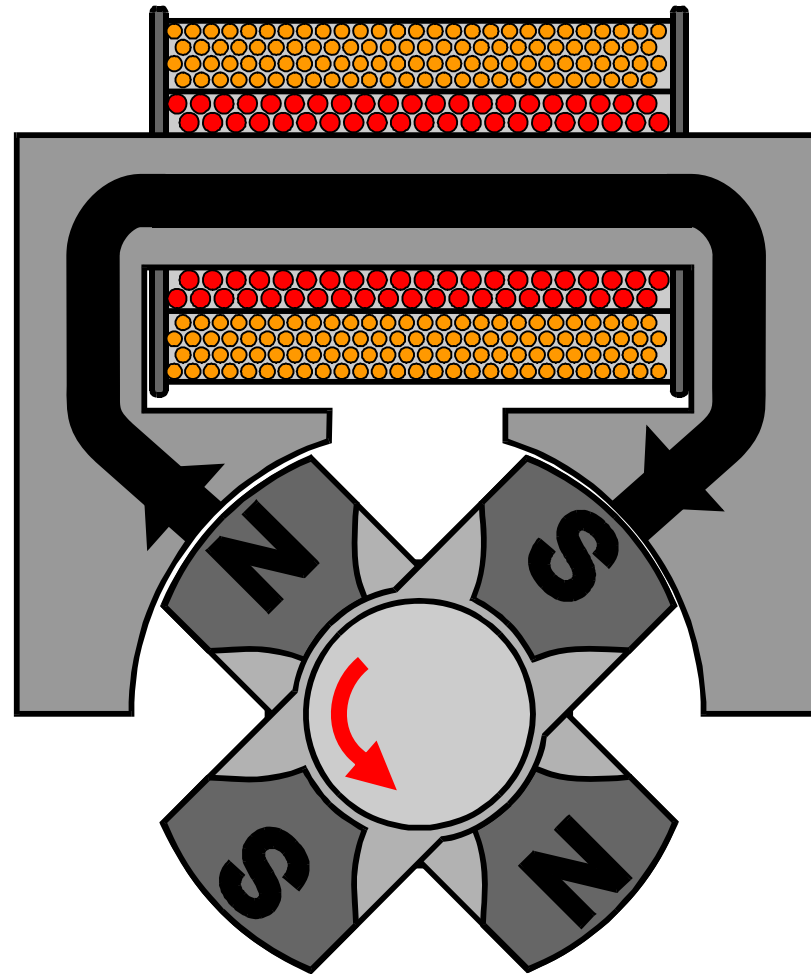

The magnetic field passes through soft iron core again

EMF produced in the coil windings again

IGNITION SYSTEM

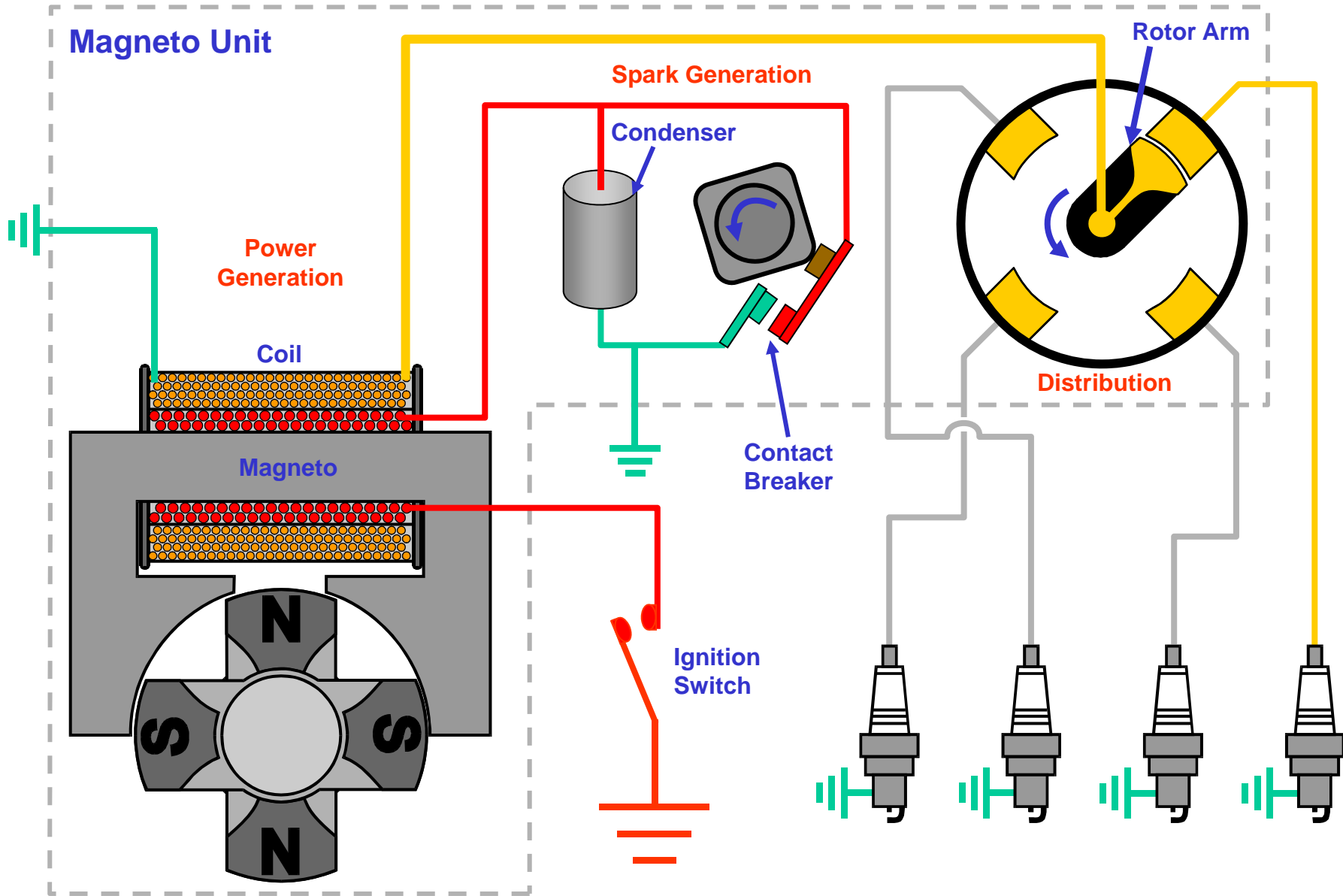

IGNITION SYSTEM – Magneto System

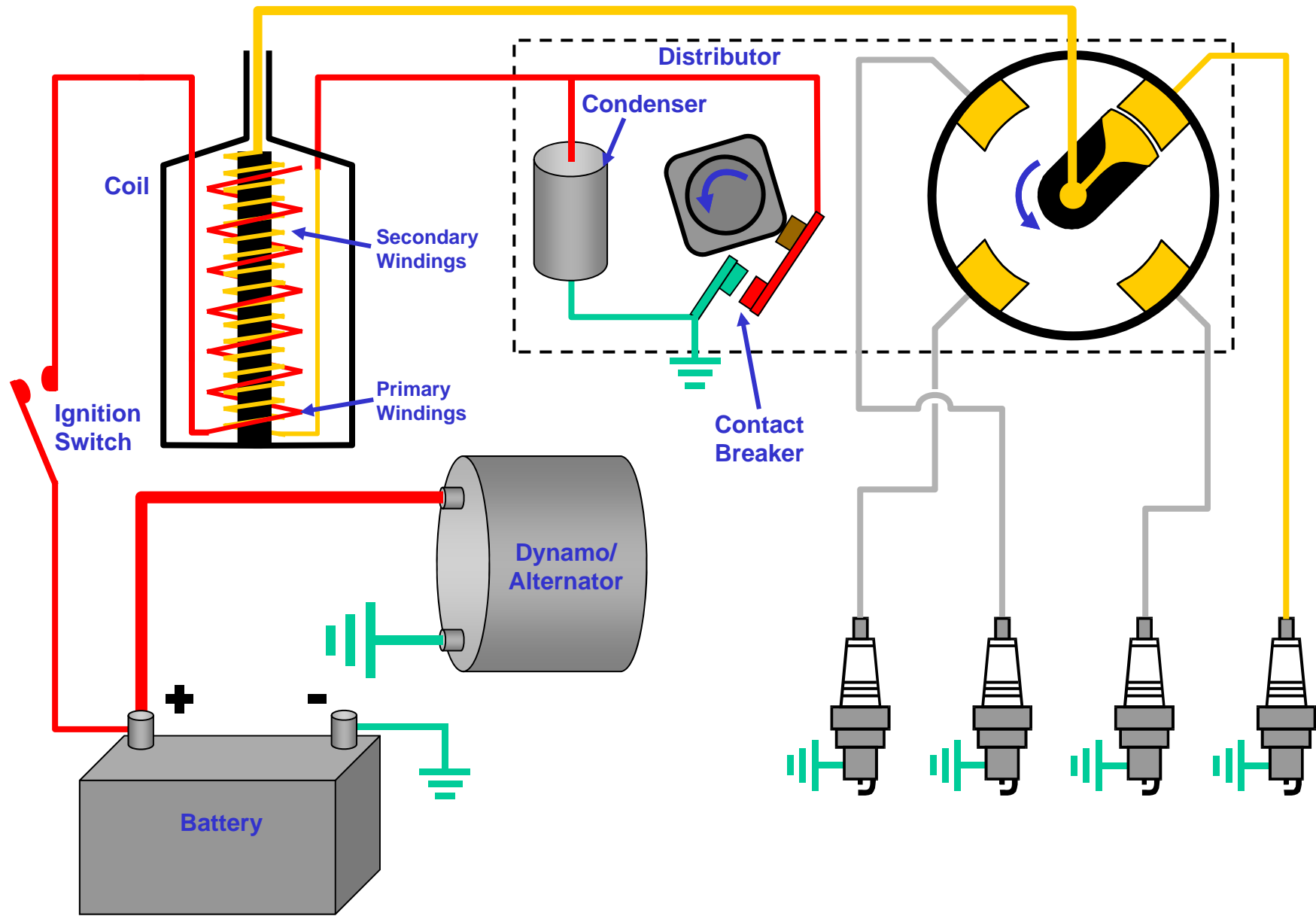

IGNITION SYSTEM – Dynamo/Alternator System

Typical Distributor

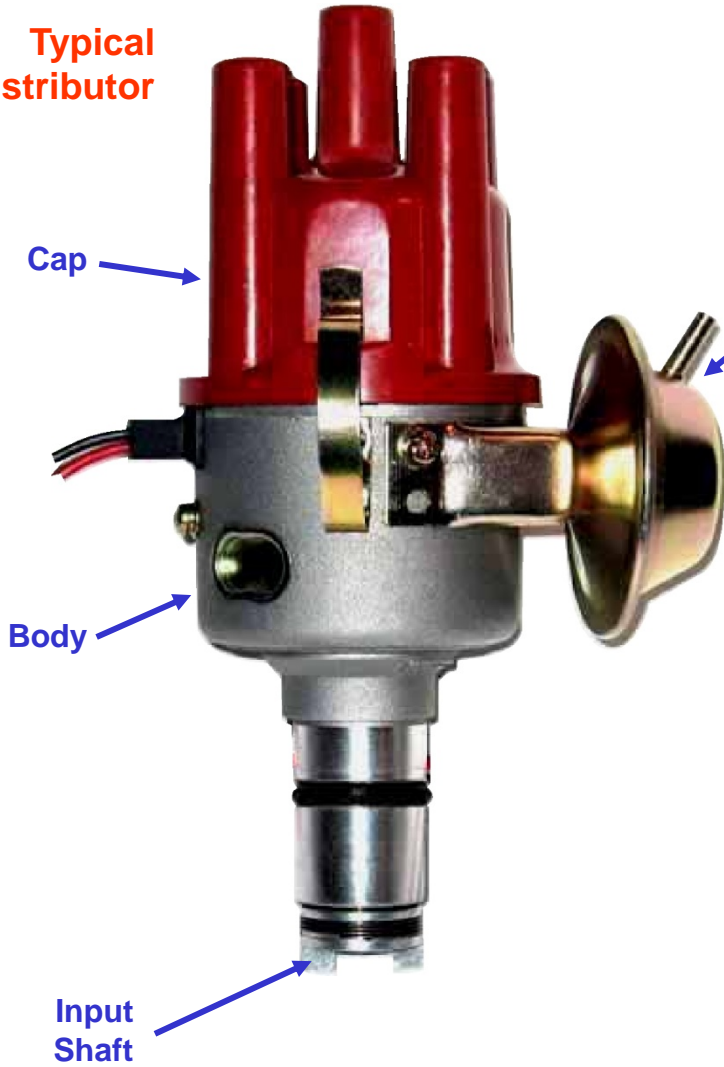

Vacuum Advance

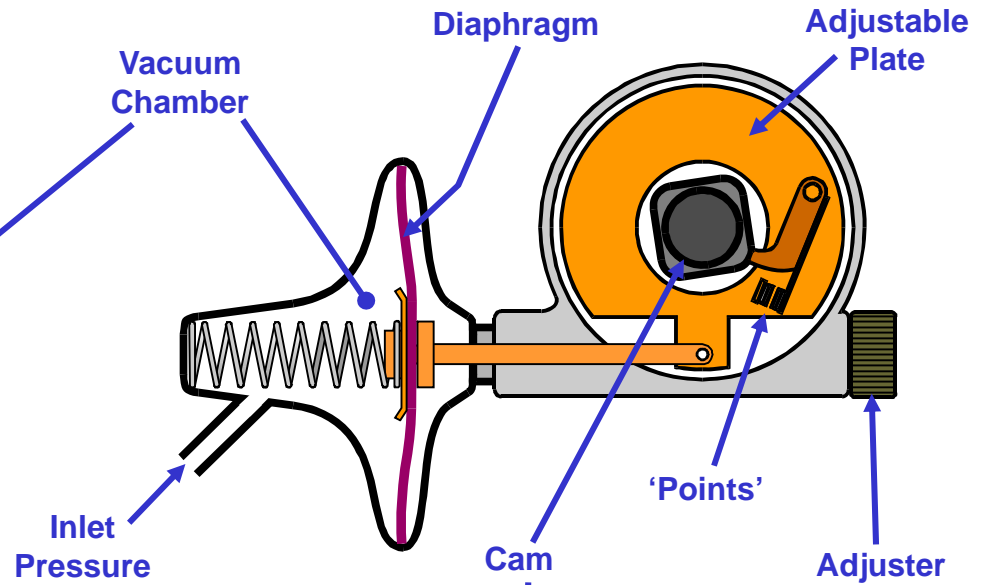

Centrifugal Advance

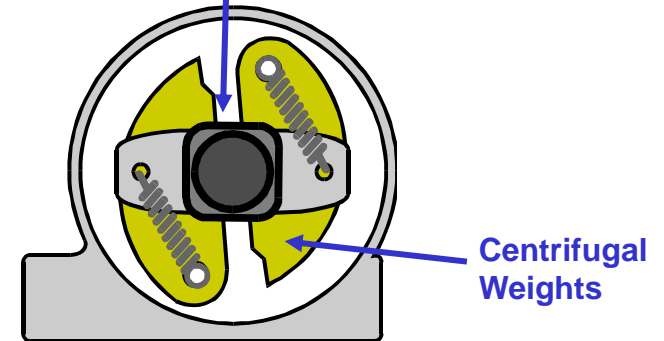

IGNITION SYSTEM – Distributor

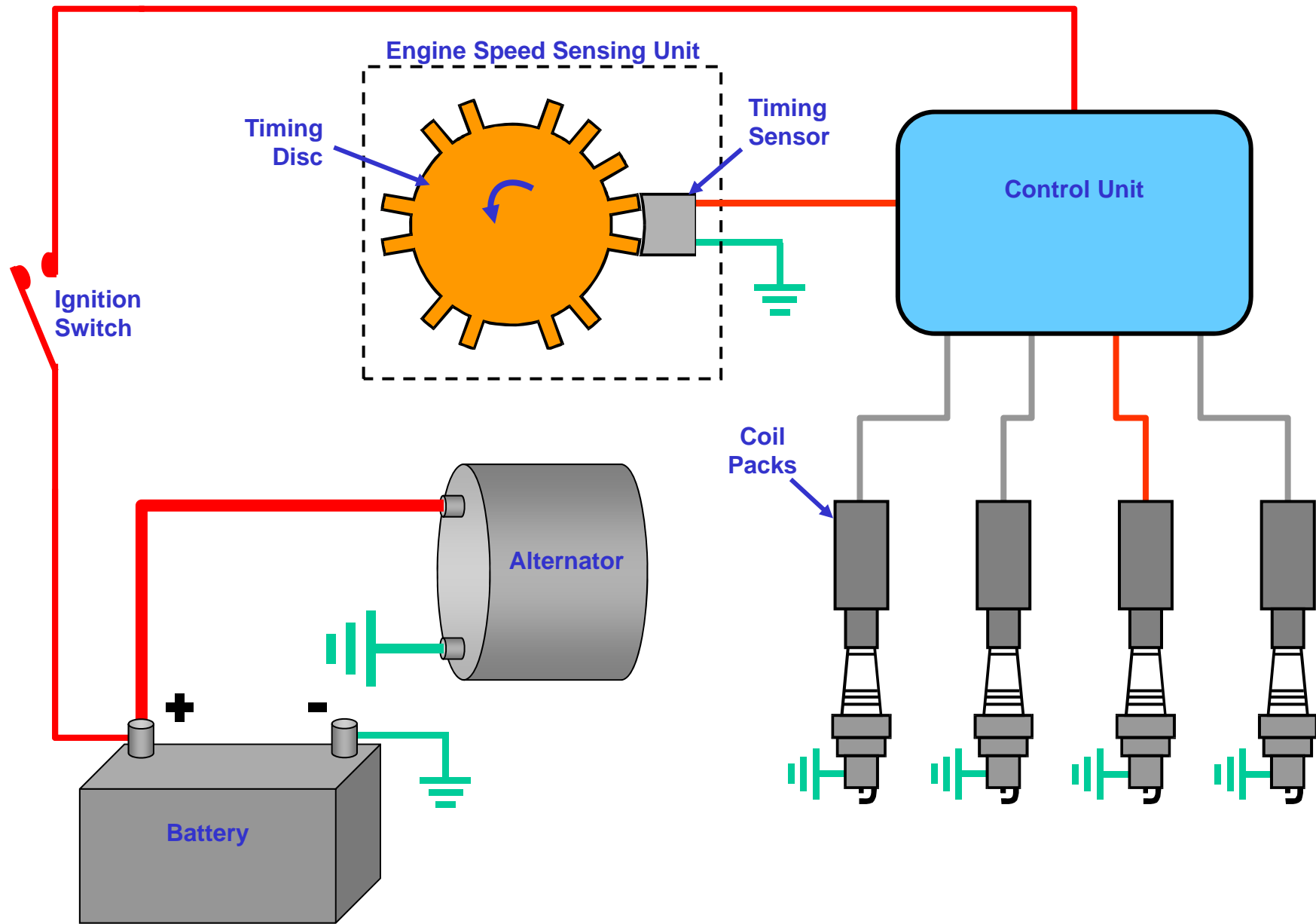

IGNITION SYSTEM – Electronic Systems

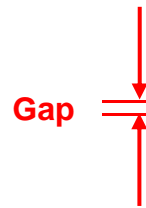
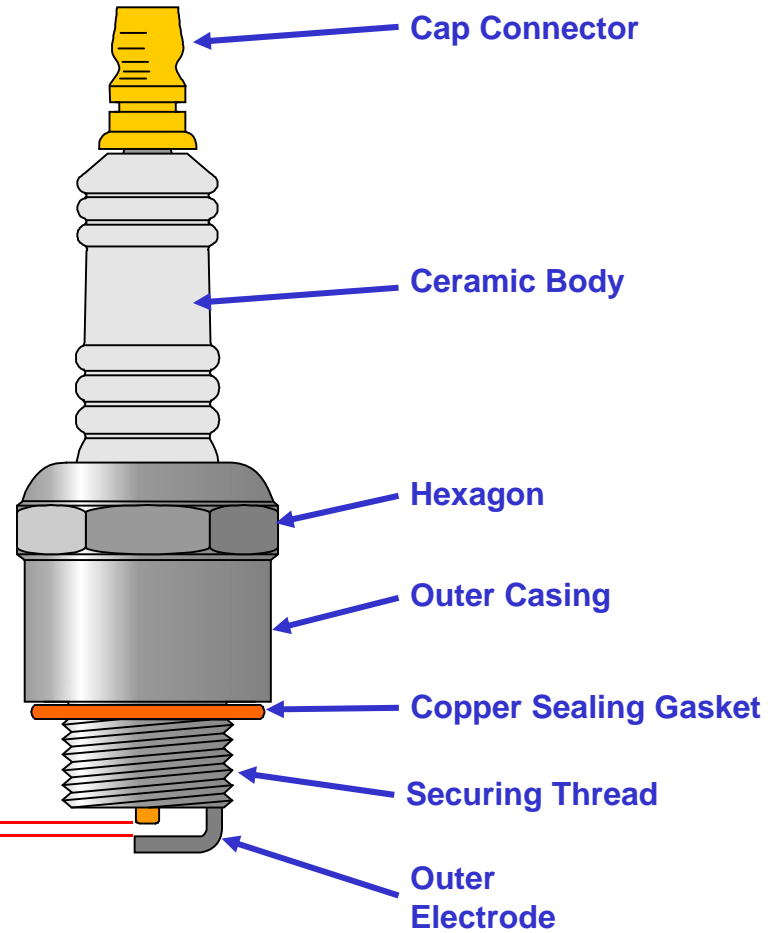

IGNITION SYSTEM – Spark Plug



**Change Spark Plugs
at specified times**

**Make sure the correct
Spark Plug is fitted**

**These surfaces must be
kept clean**

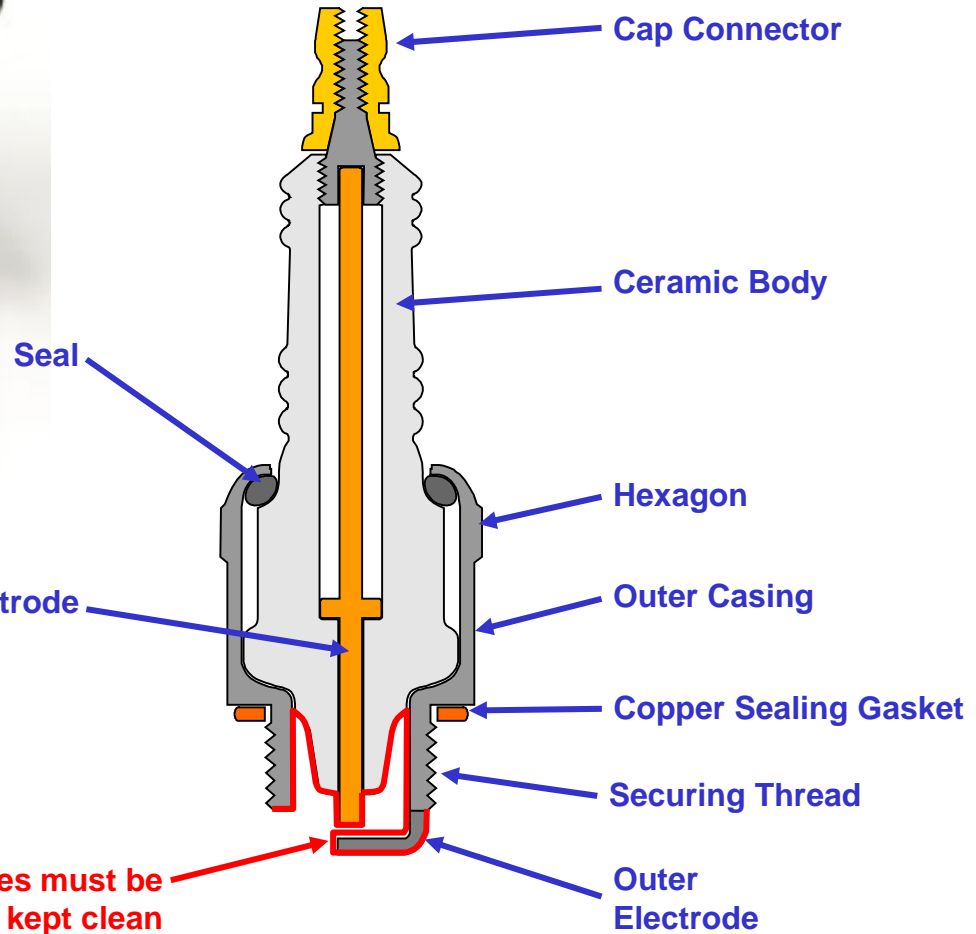

IGNITION SYSTEM – Spark Plug

Any Questions?